

WMP-171/S/Plus

17" Intel Core 2 Duo Medical Panel PC



Web camera

: USB2.0 2M module

TV tuner

: PCI type
(NTSC/PAL/SECAM)

Wireless LAN

: MiniPCI interface 802.11b/g/n
with build in antenna

Features

- 17" medical grade panel PC
- Medical certification compliance (EN60601-1 / UL60601-1)
- Anti-bacteria coating
- High Performance Intel Core 2 Duo Mobile Processor
- Supports PCI Expansion
- HDD Anti-vibration mechanism
- IP65(IP65 at front panel) / IPX1 compliance
- WebCAM (Optional)
- Supports 802.11b/g/n Wireless Solution with internal antenna (Optional)
- Lower Noise Fan Design

System

CPU	Intel® Core™ 2 Duo 2.2G CPU Intel® Celeron-M 2.0G CPU
FSB	533MHz / 800MHz
Chipset	Intel® GME965 chipset + ICH8M
BIOS	Award BIOS, ACPI supported
VGA	Intel® GME965 integrated VGA (X3100)
DVI	One DVI 29 pin output
Audio	Realtek ALC286 Audio Codec, 2+2 watts power amplifier
LAN	Realtek RTL8111B Gigabit Ethernet x 2
Memory	Two Dual Channel DDR2 SODIMM socket supports up to 4GB
I/O	ICH8M
Serial ATA	Port x 1 with 150 MB/s transfer rate x 1
USB	6 USB 2.0 ports (4 ports in the rear I/O region, 2 ports with on-board pin headers)
WDT	Generates system reset; 256 segments, 0, 1, 2...255 sec.

Expansion

PCI x1	PCI 2.2 expansion slot x 1 (None for 171S)
Mini-PCI	32-bit Mini-PCI socket x 1

External I/O

VGA	DB-15 x 1
DVI	DVI output x 1
Audio Jack	3.5mm phone jack connector (Line-in, Line-out, and Mic-in)
USB	USB 2.0 x 4
COM	x 3 for WMP-171 x 2 for WMP-171S x 2 isolated for WMP-171Plus
KB/Mouse	PS/2 Connector x2 for keyboard/mouse
LAN	RJ45 x2 for Gigabit Ethernet
Power	DC-In connector x 1
Switch	Reset key
Speaker	2W x 2
Front Bezel	LED Indicator/ Hot Key (Power Button/ Audio adjustment +/- / brightness +/-)

LCD and Touch

Panel	17", 1280 x 1024, 380 nits
Touch	Resistive type

Storage

HDD	2.5" SATA HDD drive bay x 1 (with anti-vibration mechanism)
CF	1 x bootable Compact Flash slot for CF type I/II storages (None for 171S)

Mechanical & Environmental

Power Input	DC12V-28V
Power Adapter	AC 90 ~ 264V / 47 ~ 63 Hz / DC output 12V
Operation Temperature	0~40°C
Operation Relative Humidity	10%~90%, non-condensing
Dimension	420 x 360 x 83mm (W x H x D)
Weight	6.5kg without AC adapter
Mounting	VESA Mount 75/100mm
Regulations	FCC-B,CE, VCCI EN60601-1 / EN60601-1-2 / UL60601-1

IP65 at front / IPX1 compliance

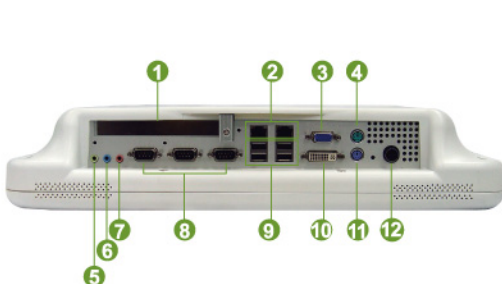

- ① PCI Slot
- ② Giga LAN
- ③ VGA
- ④ PS2 Mouse
- ⑤ Line-out
- ⑥ Line-in
- ⑦ Mic
- ⑧ RS232
- ⑨ USB
- ⑩ DVI
- ⑪ PS2 K/B
- ⑫ Power DC-in
- ⑬ Rubber cover
- ⑭ I/O cover

WMP-171/S/Plus

17" Intel Core 2 Duo Medical Panel PC

Drawing

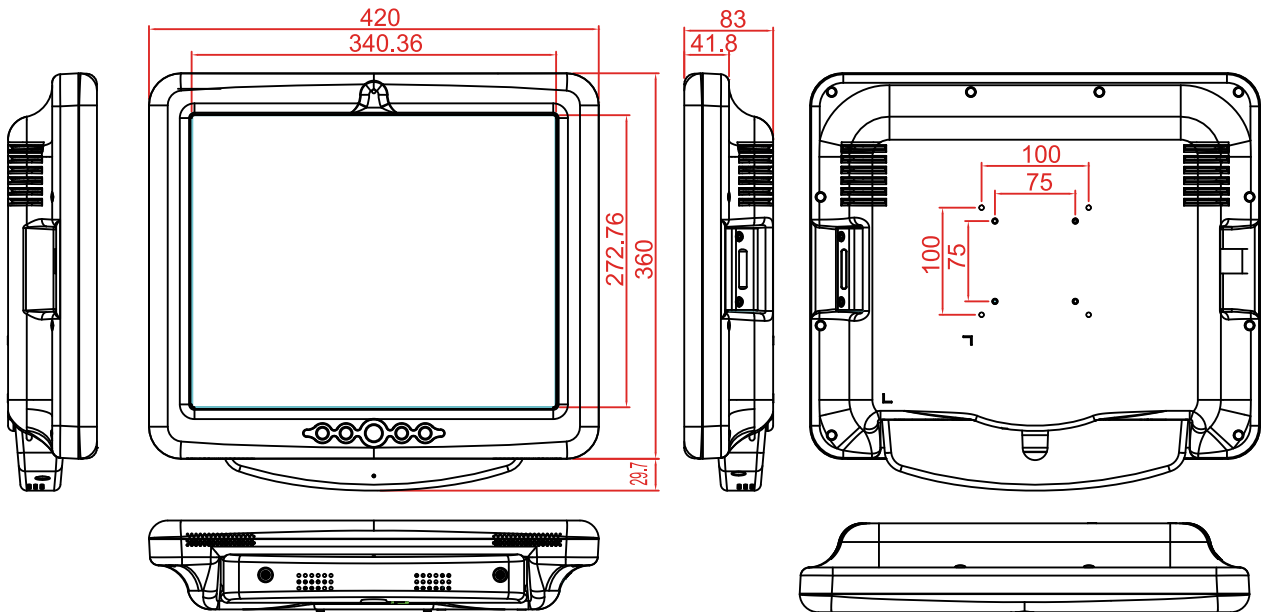

Optional

- 2M Webcam
- WLAN card
- TV tuner card/video capture card
- Smart card reader
- IO cover with microphone
- Stand with Anti-Bacteria coating
- Temper glass on LCD
- DC to DC cable

Key Features



HDD Anti-vibration



Wireless LAN



TV tuner or Video Capture

Ordering Information

1. WMP-171: C2D 2.20G Mobile CPU-1G RAM-160G HDD
2. WMP-171S: C2D 2.20G Mobile CPU-1G RAM-160G HDD
3. WMP-171Plus: C2D 2.20G Mobile CPU-1G RAM-160G HDD



Wincomm Corporation

3F, NO. 14, Prosperity Road II, Science-Based Industrial Park,
Hsinchu, Taiwan 30078, R.O.C

Tel : +886 3 578 0000 Fax: +886 3 578 0295

Web: www.wincomm.com.tw

Contact: sales_support@wincomm.com.tw