



Features

- Intel® Skylake/Kaby Lake Core i7/i5 Processor
- 17" 1280x1024 LCD Panel
- Highest Level EMC 4.0/ Safety 3.1 Certification Ready
- Support Intel® vPro by Optional Core i7/i5 CPU
- Anti-Bacteria Plastic Housing Including Touch
- Friendly Design of Front Various Hot-Keys
- Front IP65, IPX1 for Whole System
- Optional PCI-Ex16 Expansion Slot
- Optional Built-In Battery Pack
- Optional 4KV LAN/COM/USB Isolated I/O
- Support RAID 0,1

Specification

Model	WMP 17F IPOA (STD)	WMP 17F IPOB (ISO)
Main System		
CPU / Chipset	LGA1151 package 6 th /7 th generation Intel® Core i7/i5/i3/Celeron processor	
Graphic	Intel® integrated HD Graphics	
RAM	Two 2400 MHz DDR4 SODIMM socket support dual Channel, non-ECC, up to 32GB	
OS Support	Windows 7 embedded, Windows 7 pro, Windows 8 embedded, Windows 8 industrial, Windows 10	
Storage	2.5" SATA HDD drive bay x 1 ,mSATA via mini PCI-E x 1, Optional 2 nd 2.5" HDD	
Expansion	PCI-e(x16) x1 (ISO I.O. module occupy PCI-e slot), Mini PCIe x2 Optional Network Interface: 802.11 ac/a/b/g/n WLAN + Bluetooth module	
Display Size	17" wide TFT-Color LCD	
Display	1280 x 1024 (SXGA), 16.2M colors (MVA, 8 bit), 170(H) / 160(V), 350 nits (Typ. Center point), CR:1000 : 1 (Typ)	
Touch Screen	5 Wire Resistive Touch Panel / Light Transmission: 81% ± 3% / Hardness: ≥ 3H, Life: 35M times	
I.O. Ports		
USB	USB3.0 x 4	USB3.0 x4, ISO USB2.0 x 2
COM	RS232/422/485 x 1:Support RS485 Auto flow control function, RS232 x 1	RS232/422/485 x 1, RS232 x 1, ISO RS232/422/485 x 1, ISO RS232 x 1
LAN	RJ45 X 2	Rj45 x 1, ISO RJ45 x 1
Audio/ Video	3.5mm phone jack connector * 2 (Line-out, Mic-In)/ DVI-D x 1 + DP x 1	
Control Hot Key (R to L)	Brightness down/Brightness up // Power // Volume down/Volume up	
Mechanical and Environmental		
Cooling	Smart Fan	
Power Input	DC-In x 1, DC 7~32V input	
Power Adapter	AC input 100~240V / 47 ~ 63 Hz / DC output 24V, 100W	
Temperature	Operating Temperature: 0~40°C (chamber) / Storage Temperature: -20~60°C	
Humidity	Operating & Storage:10 ~ 90%, non-condensing	
IP Rating / Housing	IP65 (Front Side), IPx1 whole system / Front: Full flat design/ Touch (standard)/ Glass(customized); Rear: Plastic White w/Anti-bacteria (MRSA), Housing	
Dimensions (Net)	420mm (H) x 360mm (V) x 83mm (T)	
Weights (Net)	7 kg (w/o power adapter/battery pack)	
Mounting	Optional Stand, VESA 75/ 100	
Certification	cULus/EN/UL/60601-1, 60601-1-2 4th Edition, IEC62133, FCC/CE/VCCI Class B, Energy Star 6.1 Compliance	

WMP-17F

Medical AIO Core™ Fan

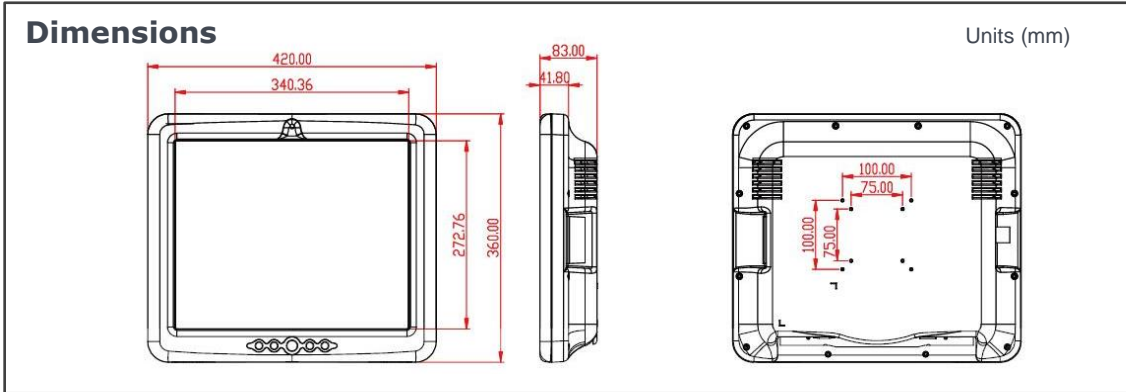

Major Options	
Add On Parts	<ol style="list-style-type: none"> 3.2M AF Webcam(USB) TPM 2.0 module Wireless or Wireless + BT kit RFID (13.56MHz) PCI-E [x16] riser card Equipotential Terminal Pin Battery pack (100W max.) Support add-on card 18W max Full HD Capture Card mSATA module 2.5" SSD 4KV Isolation Card x 1 (Isolation COM x 2, Isolation LAN x 1, Isolation USB x 2)
Power Cable	<ol style="list-style-type: none"> Power adapter w/ 2m extension cable Power plug holder Microphone on I/O cover or I/O cover without Microphone
Optional kits	<ol style="list-style-type: none"> Anti-bacteria Stand VESA Wall Mount
Customization	<ol style="list-style-type: none"> Temper Glass Extra USB x 2 or COM x 2

Order Information

Item	Configuration
WMP-17F – IR0A	Core i5-6500TE 2.3GHz / 4G RAM / 500G HDD / Full flat R touch / STD
WMP-17F – IR0A	Core i7-6700TE 2.4GHz / 4G RAM / 500G HDD / Full flat R touch / STD

STD IO Parts

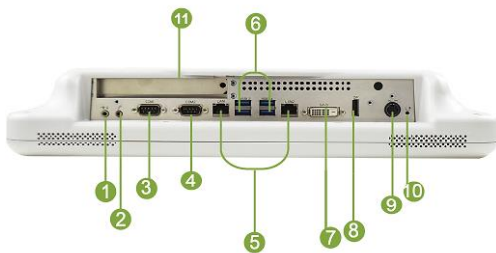

- ① Line-out
- ② Microphone-in
- ③ RS232/422/485
- ④ RS232
- ⑤ LAN x 2
- ⑥ USB 3.0 x 4
- ⑦ DVI-D
- ⑧ DP x 1
- ⑨ DC-in
- ⑩ Reset
- ⑪ PCI-E[x16] expansion

