

WLP-6821-12

12.1" VIA C7 Fanless & Ultra Slim Panel PC



Features

- True Fanless Thermal Solution
- VIA C7 1.0G or 1.5G CPU
- IP65 / NEMA4 Water / Dust Proof on Front & Rear Bezel
- LAN / CF / Audio / USB2.0 / Mini-PCI interfaces
- Resistive and Capacitive, IR touch screens are optional
- Anti-vibration HDD



System

CPU	Onboard VIA C7 1.0 GHz (9W) or 1.5GHz(12W)
Chipset	VIA CN700 + VT8237R plus
BIOS	AMI BIOS Support ACPI Function with PXE function
Cache	Level-1 128K / Level-2 128K (CPU integrated)
VGA	VIA CN700 built-in AGP 8X graphics, shared system memory up to 64MB
Audio	AC97 Audio Codec, 2+2 watts power amplifier
LAN	VT6103 10/100Base-Tx Fast Ethernet PHY, support WOL/PXE function
Memory	1 x DDR2 533 SODIMM socket supports up to 1GB memory
I/O	VIA VT8237R plus
IDE	UDMA 133 EIDE interface x 2 Serial ATA interface x 1
GPIO	4-bit input, 4-bit output
WDT	1~255 minutes, software programmable

Storage

HDD Internal 2.5" HDD drive bay x 1

Expansion

Mini-PCI 32-bit Mini-PCI socket
(support 802.11b/g and DVB modules) x 1

CF Bootable Compact Flash slot for CF type I/II storages x 1

LCD Panel

Size	12.1"
Resolution (pixel)	SVGA (800 x 600)
Active Area (mm)	246.0 x 184.5
Pixel Pitch (mm)	0.3075 x 0.3075
Number Of Colors	262k / 16.2M
Viewing Angle (H/V)	160 / 110
Brightness (cd/m²)	400
Contrast Ratio	500:1
Response Time(ms)	35
Backlight	2 lamps/2 side

Touch Panel

Characteristics	Resistive	Capacitive	Infrared touch (IR)
Touch Resolution	4096x4096	4096x4096	4096x4096
Stylus use possible beyond finger	No Limitation, can use any stylus	Need special conductive stylus	No limitation, can use any stylus
Glove use possible	Any type glove	Only very thin latex glove	Any type glove
Light transmittance	80±3%	90% above	100%
Hardness	3H	7 Mohs	7 Mohs
Accuracy	98.50%	99%	
Response time	20 ms	3 ms	
Touch screen Life	8 wire 2 million touches 5 wire 35 million touches	Specified to over 200 million touches Coatings can wear	Large number of photo diodes and photo transistors effect long-term reliability. Specified to over 500 million touches Coatings can wear

External I/O

USB USB 2.0 x 4

COM DB-9 x 3 (RS-232 x 2, RS-232/422/485 x 1)

LAN RJ-45 x 1

KB/Mouse PS/2 Keyboard & Mouse x 1

Audio Line-in, Line-out, and Mic-in audio jacks

Power DC-In connector x 1

Switch ATX power switch & RESET switch

Mechanical & Environmental

Power Input DC 12V ~ 28V

Power Adaptor AC 90 ~ 264V / 47 ~ 63 Hz

Operating Temperature 0~40°C (fanless)
0~50°C (for CF/DOM/Wide temperature HDD storage)

Storage Temperature -20~80°C

Relative Humidity 10%~90%, non-condensing

Dimension 369(W) x 290(H) x 55(D) mm

Weight 4.8 kg

Regulations FCC-A , CE , VCCI , UL/cUL

WLP-6821-12

12.1" VIA C7 Fanless & Ultra Slim Panel PC

Drawing

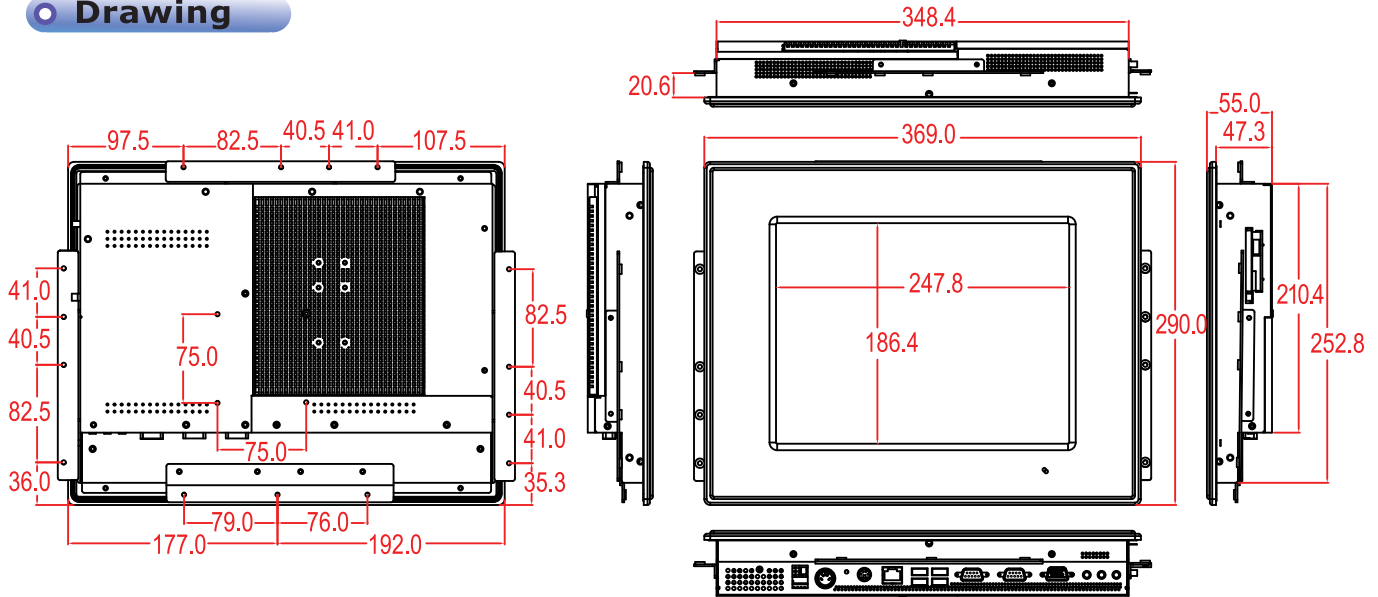

Fully-integrated I/O

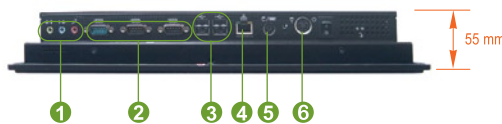
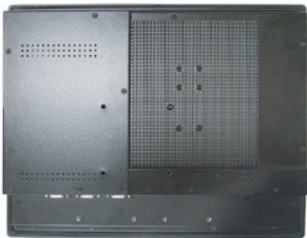

- ① Line-in, Line-out, Mic-in
- ② COM port
- ③ USB
- ④ RJ-45 interface
- ⑤ PS2 K/B & Mouse
- ⑥ DC Power jack

Key Features



HDD Anti-Vibration



Ultra Slim and Rugged Design



Modulated touch design

1. Resistive touch
2. Capacitive touch
3. IR touch

Built-in Touch Screen

Ordering information

1. WLP-6821-12-**1****2****3****4**-C7 1.0G-512-160GB
2. WLP-6821-12-**1****2****3****4**-C7 1.5G-512-160GB

1 B: Panel Mount type
N/A: Open frame type

2 K: Black color bezel
S: Silver color bezel

3 R: Resistive touch
C: Capacitive touch

4 T: with touch screen
N/A: without touch screen

IR touch screen is also available



Wincomm Corporation

3F, NO. 14, Prosperity Road II, Science-Based Industrial Park,
Hsinchu, Taiwan 30078, R.O.C

Tel : +886 3 578 0000 Fax: +886 3 578 0295

Web: www.wincomm.com.tw

Contact: sales_support@wincomm.com.tw