

WTP-8B66-15W

15" Intel Bay Trail Stainless Wide Temp. Full IP66 Fanless Panel PC

Outline Dimension

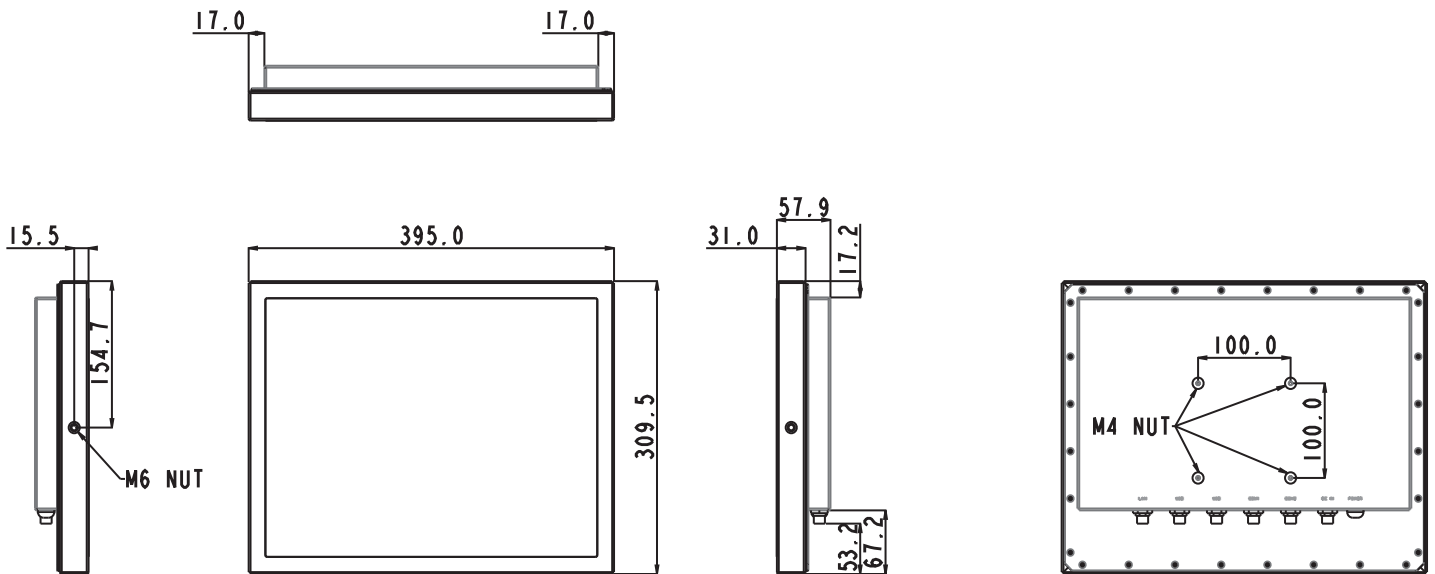

Packaging & Options

Packaging System, power adaptor, AC power cord, DVD (drivers & manual)

Options

- Wireless or Wireless + BT kit (2 ant)
- M12 to 1x COM cable
- M12 to 1x USB cable (1 USB Port)
- M12 to 2x USB cable (2 USB Ports)
- M12 to 1x LAN cable
- (cable length is 2 meters, Waterproof)
- Wall mount / table mount bracket

Customization

- 1000 nits high brightness LCD
- Sunlight readable optical bonding
- Anti UV coating
- Full flat PCT touch screen IP69K
- LCD Auto dimming
- LCD Super dimming (Low brightness)

I/O & Control Keys

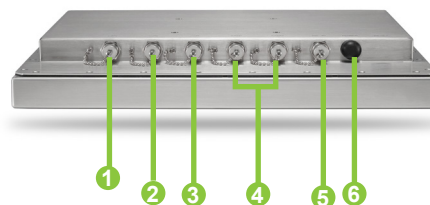

- 1 Giga Lan
- 2 USB (1/2)
- 3 USB (3/4)
- 4 COM x 2
- 5 DC-in
- 6 Power on/off



Table Mount



Wall Mount

Ordering Information

WTP-8B66-15 W

15" FANLESS

Atom E3845 CPU, Wide temp 2G RAM, wide temp 128G SSD



Wincomm Corporation

3F, NO. 14, Prosperity Road II, Science-Based Industrial Park,
Hsinchu, Taiwan 30078, R.O.C
Tel : +886 3 578 0000 Fax: +886 3 578 0295

Web: www.wincomm.com.tw

Contact: sales_support@wincomm.com.tw